

THIS DRAWING IS UNPUBLISHED. RELEASED FOR PUBLICATION  
 © COPYRIGHT BY TYCO ELECTRONICS CORPORATION. ALL RIGHTS RESERVED.

LOC	DIST	REVISIONS					
G	14	P	LTR	DESCRIPTION	DATE	DWN	APVD
		F		REV PER 0G3A-0640-04	13AUG04	JR	TM

<b>AMP</b> WIRE RANGE	Listed FILE E13288	LR7189 Certified
22-16 AWG SOLID OR STRANDED	22-16 AWG SOLID OR STRANDED	22-16 AWG SOLID OR STRANDED

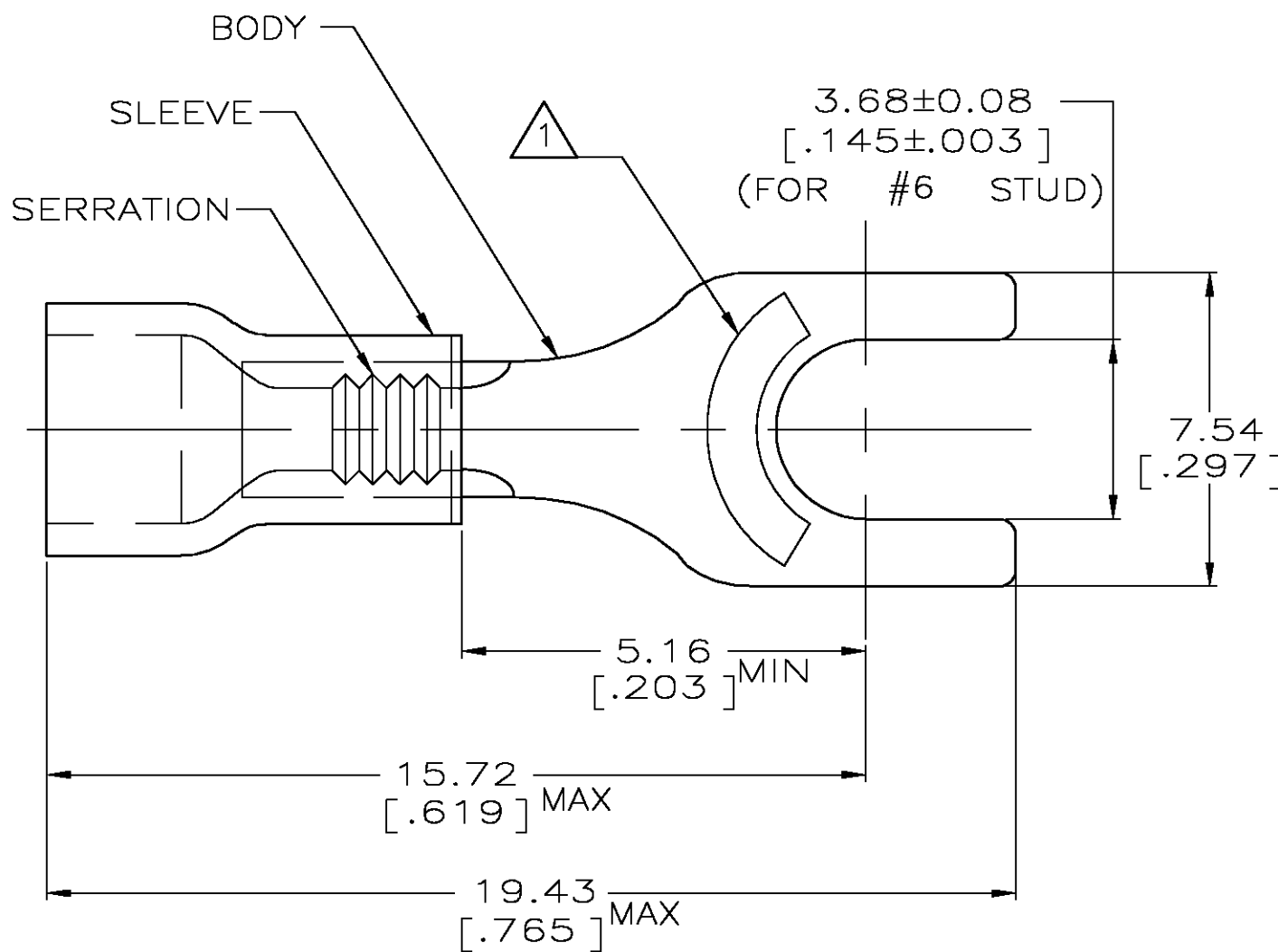

- △ 1 STAMP AMP 22-18\* APPROX AS SHOWN  
22-16 TERMINALS ARE STAMPED 22-18 IN  
ACCORDANCE WITH MILITARY SPEC MIL-T-7928  
COMMERCIAL WIRE RANGE IS 22-16
- 2 WIRE INSUL DIA: 2.03-3.18 [.080-.125]
- 3 TONGUE MATL THK: 0.79 ± 0.05 [.031 ± .002]
- △ 4 MATERIAL: BODY - CU PER ASTM B152  
SLEEVE - PVC, COLOR - RED

100	LOOSE PIECE, BOX	8-327735-1
5000	ON TAPE, REEL	2-327735-1
1000	LOOSE PIECE	327735
QTY	PACKAGE TYPE	PART NO

<b>AMP INCORPORATED CUSTOMER SERVICE SYSTEMS</b>		MAX RECOMMENDED OPERATING TEMPERATURE: 105°C [221°F]	THIS DRAWING IS A CONTROLLED DOCUMENT.		DWN G VINSON 28NOV94	Tyco Electronics Corporation Harrisburg, Pa 17105-3608			
FOR ADDITIONAL PRODUCT INFORMATION OR COPIES OF DRAWINGS AND TECHNICAL DOCUMENTS	PRODUCT INFORMATION CENTER 1-800-522-6752	VOLTAGE RATING: 600V MAX (1000V FIXTURE OR SIGN)	DIMENSIONS: mm [INCHES]	TOLERANCES UNLESS OTHERWISE SPECIFIED:	CHK M ELLIS 28NOV94	NAME			
FOR APPLICATION TOOLING INFORMATION	TOOLING ASSISTANCE CENTER 1-800-722-1111	CIRCULAR MIL AREA: 0.26-1.65mm² [509-3260] SOLID OR STRANDED		0 PLC ± - 1 PLC ± - 2 PLC ± 0.20 [.008] 3 PLC ± - 4 PLC ± - ANGLES ± -	APVD G NGO 28NOV94	TERMINAL, SPADE, PLASTI-GRIP WIRE SIZE 22-16 AWG			
FOR ORDER ENTRY	1-800-526-5142	THIS DRAWING IS A CONTROLLED DOCUMENT FOR AMP INCORPORATED. IT IS SUBJECT TO CHANGE AND THE CONTROLLING ENGINEERING ORGANIZATION SHOULD BE CONTACTED FOR THE LATEST REVISION.	MATERIAL - 4	FINISH TIN PER ASTM B 545	PRODUCT SPEC UL 486A	SIZE A3	CAGE CODE 00779	DRAWING NO C-327735	RESTRICTED TO -
CUSTOMER DRAWING					WEIGHT -	SCALE 6:1	SHEET 1 OF 1	REV F	